

**neptune®** Parts List for  
**Type S Magnetic Drive  
 Flowmeters  
 Sizes 1-1/2" & 2"**

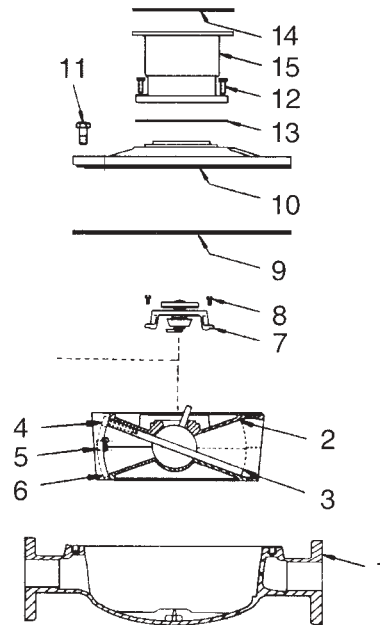

Index	Description	Part Number	
		1-1/2"	2"
1	Main Case	4887-007	4890-008
2	Measuring Chamber w/ Ryton Disc	788-143	818-137
3	Disc Piston Complete	1410-040	1416-043
4	Roller, Thrust	787-014	817-015
5	Screw, Chamber Assembling	8302-111	8302-111
6	Bearing Plate, Thrust Roller	1994-008	1995-007
7	Drive Assembly (600 Series Register)	100661-001	100652-001
8	Screw, Drive, No. 2 x 1/4" Type "U"	41692-001	41692-001
9	Gasket, Main Case	4863-008	4864-011
10	Cover, Main Case	100659-001	100650-001
11	Bolt, Main Case, Hex Head 7/16- 14 x 1-1/4"	100071-042	100071-042
12	Screw, 1/4-28 unf-2A fil hd 3/4 long (600 Series)	100061-025	100061-025
13	Gasket, Lower	100529-001	100529-001
14	Gasket, Upper	100530-001	100530-001
15	Gear Train for 600 Series		
	1 USG	100526-006	100526-005
	10 Liter	100526-008	100526-008
16	600 Series Register Complete (not shown)		
	USG	100498-001	100498-001
	10 Litre	100498-005	



**U.S.A./International**  
1310 Emerald Road  
Greenwood, SC 29648-8800  
Tel.: Toll-Free (800) 833-3357  
(864) 223-1212  
Fax: (864) 223-0341

© 2002 Actaris Neptune Liquid Measurement Division 300 07/02  
Specifications subject to change without prior notification.

