

M-150
Rev. C
MP Oscillating Piston Flowmeters:
1/2" Type MP
1" Type MP
2" Type MP
3" Type MP

Itron

Operating and Maintenance Manual for
neptune MP Oscillating Piston Flowmeter



TABLE OF CONTENTS

DESCRIPTION	PAGE
General Information	1
Installation	1
Calibration	2
Register Maintenance.....	3
Pulsmate Electronic Register	3
800 Series Register	4
1" MP w/Double Trip Auto-Stop Valve	5
2" MP w/Single Trip & Double Trip Auto-Stop Valve	6-8
3" MP	9-13
600 Series Register	14
Operational Checks	15
Gear Train Maintenance	15
Cleaning the Flowmeter.....	16
General Maintenance	17
Troubleshooting	18

GENERAL INFORMATION

This manual is intended to be a guide for the proper operation and maintenance of the 1/2", 1", 2" and 3" MP Flowmeters and accessories, as described in Form TS-150.

The MP Flowmeter is a carefully designed flowmeter based on the tried and true oscillating piston principle and incorporates the very best materials and design features available. In the MP Flowmeter, an oscillating piston is contained within a rugged main housing which also serves as the measuring chamber. This approach simplifies the design and minimizes flowmeter maintenance.

The oscillatory motion of the piston rotates a drive arm which is part of a magnetic drive assembly contained within the cover of the flowmeter. The rotation of the magnet in this assembly causes rotation of a similar magnet in either an external gear train or in a totalizer register.

Various readout options and accessories are available.

INSTALLATION

Please review the following installation guidelines carefully before installing your flowmeter. Afterwards, if you have questions or concerns, please contact your local Itron distributor for assistance.

STRAINER

Plan the installation in such a way as to allow a strainer to be coupled directly to the inlet of the flowmeter. Where this is not possible, any piping before the flowmeter should be thoroughly cleaned out. The use of at least a 40 mesh strainer is required to validate the warranty.

Be careful to allow room for easy removal of the strainer basket.

AIR/AIR RELEASE

The presence of air in the system can cause overspeeding and damage to the flowmeter. Air will also cause the register to over record. The use of an air release will assist in preventing these problems. Also, the use of a venting valve will aid in preventing air related problems during start-up of flow.

Air releases cannot be supplied for all liquids, but where an air release valve is used, it should be installed in a position as close as possible to the inlet of the flowmeter. This will insure the removal of the greatest amount of air from the liquid before metering.

VALVES

The metering system should be furnished with and controlled by a shut-off valve on the downstream side of the flowmeter to insure that the piping and the flowmeter are filled at all times. A valve is needed to operate flow to avoid overspeeding in most installations.

CONNECTIONS/PIPING

Use pipe compound sparingly on male threads only.

A bypass connection installed around the flowmeter should be monitored frequently since the valve in such a bypass may eventually leak, work open, or be left open.

GENERAL MAINTENANCE

INSTALLATION

Before Installing the Flowmeter

Piping

Secure the connecting piping firmly to prevent strain on the flowmeter casing. Use self-aligning couplings and expansion joints in long piping runs to allow for expansion and contraction caused by temperature changes.

Provide the metering system with means for pressure and relief or escape of trapped liquid caused by temperature expansion. Pressure build-up can be eliminated by the use of valves equipped with pressure relief at selected sections of line that may be blocked between valves. If the flowmeter is to be operated under extremes of environment (*dirt, dust, water, freezing, etc.*) an enclosure or other protection should be provided.

Thoroughly clean system and all piping, especially on the inlet side of the flowmeter. When possible, install a length of pipe (spool-piece) in place of the flowmeter and flush out the piping thoroughly before the flowmeter is installed. The majority of service calls on new installations are eliminated if these directions are followed.

Connect the flowmeter so that its inlet and outlet are correctly located. (*These are clearly marked.*) Do not install the flowmeter backwards. Should it be necessary to change the direction in which the register will face, turn it as described under "Register Maintenance."

When the installation is still new, clean the strainer frequently. After the system has had a chance to be thoroughly flushed out, only periodic cleaning is necessary.

CALIBRATION

When checking the calibration of the flowmeter, use a calibrated test measure of sufficient size that the flowmeter will operate at a normal flow rate for at least one (1) minute. For checking this flowmeter, use a 10 gallon volumetric test measure of approved design (for 1/2" meter) or use a 100 or 300 gallon volumetric test measure of approved design (*a container with a conical upper portion terminating in a long narrow neck that is fitted with a sight gauge.*)

Erratic registration is an indication of trouble in the system, and is usually caused by air or dirt in the measuring chamber. Do not try to correct this by recalibrating the flowmeter, but first check for the presence of air in the line; then, if the trouble has not been found, clean the flowmeter as directed.

Over-registration is an indication of air, whereas under-registration is generally caused by dirt or pipe scale in the measuring chamber, by the liquid bypassing the flowmeter in some manner, or by a damaged or worn internal mechanism.

Consistent over-registration or under-registration indicates need for recalibration. See Form TSG-310 for recalibration procedures. These forms can be obtained from your nearest Itron distributor, or contact Itron, Inc., 1310 Emerald Road, Greenwood, SC 29646.

When Installing

Cleaning the Strainer

CALIBRATION

Erratic Registration

Consistent Over- or Under-Registration

REGISTER MAINTENANCE

Register parts are such that only minor field repairs are advisable. When a register is in need of extensive service or repair other than that for which instruction is given here, it is recommended that the register be returned to the nearest Itron distributor for repair. If a replacement register is needed, be sure to specify the exact model of the register replaced as well as the change gears in the register. See parts lists, forms: P-390 and P-300.

PULSMATE ELECTRONIC REGISTER

1/2" MP METER:

Remove the set screw from the Pulsmate and twist the register 1/8" turn counter clockwise to release the retaining spring. The Pulsmate is now free and can be withdrawn from the meter cover. The Pulsmate can be remounted in any one of 4 positions at 90° intervals on the meter cover.

1"-3" MP METER:

The Pulsmate is fixed to the meter cover by 2 clamp rings secured by 4 bolts. To remove the register from the meter, loosen the screws and disengage the clamp rings from the groove in the Pulsmate body. The Pulsmate can be positioned at any angle prior to clamping to the meter cover.

PULSMATE MAINTENANCE

The only scheduled maintenance for the PULSMATE register is periodic replacement of the battery.

Battery Replacement:

The PULSMATE has a battery monitor feature that illuminates when the lithium battery voltage approaches its end of life. A descriptor "BAT", illuminates when the battery voltage falls below this predetermined value. The low battery detector operates correctly with all power options.

The battery should be replaced within several weeks of the first occurrence of low battery warning, "BAT". Left unattended, the unit may become inaccurate, cease to operate or loose setup information or malfunction.

For additional Pulsmate Electronic Register information, see form M-302. This form can be obtained from your nearest Itron distributor, or by contacting Itron, Inc.

REGISTER MAINTENANCE

PULSMATE ELECTRONIC REGISTER

Removing the Pulsmate from the Meter

MAINTENANCE

800 SERIES REGISTER

Loosen the two clamp screws on lower front of the register. Lift the register off. On Auto-Stop models the valve linkage must first be disconnected. (*Remove cotter pin and washer at valve end.*)

When one register is removed and another substituted, (1) Check the number of teeth on the change gears. They must be the same as the gears on the old register **and on the same respective spindles**. The number of teeth is stamped on each gear. To remove these gears, close the split end of the spindle with a pair of pliers and pull off the gear. After putting on a gear, spread the end of the spindle slightly. (2) If a gear shifter ins installed, make sure that the position is the same on the new register as on the old one. Each hole is lettered for convenience.

Register masks are made of plastic and require special treatment. Instructions for cleaning are given below:

If the mask becomes soiled with grease and oil, solvents for these substances, such as kerosene or naphtha, may be used to remove dirt. However, sprays that are commonly employed in cleaning glass windshields must not be used as cleaners.

A water solution of nonabrasive soap is recommended for washing grease, oil or dirt from the mask. It is then cleaned by rubbing gently with a soft cloth, in a manner similar to cleaning window glass, rinsing the mask in clean water, and finally drying.

Scouring cleanser and similar material must not be used in cleaning the mask, since they contain abrasives that scratch the surface.

The use of solvents, such as acetone, ethyl acetate, benzene and ethylene dichloride to brighten the surface of the mask is never recommended since these substances soften the surface of the plastic.

Note: Large magnetic drive assembly accompanies 800 series register.

TO ROTATE REGISTER (1" & 2" MP)

When the flowmeter is assembled as a Left Hand assembly and it is desired to change it to a Right Hand assembly, or vice versa, proceed as follows:

VIEW LOOKING AT BACK OF REGISTER

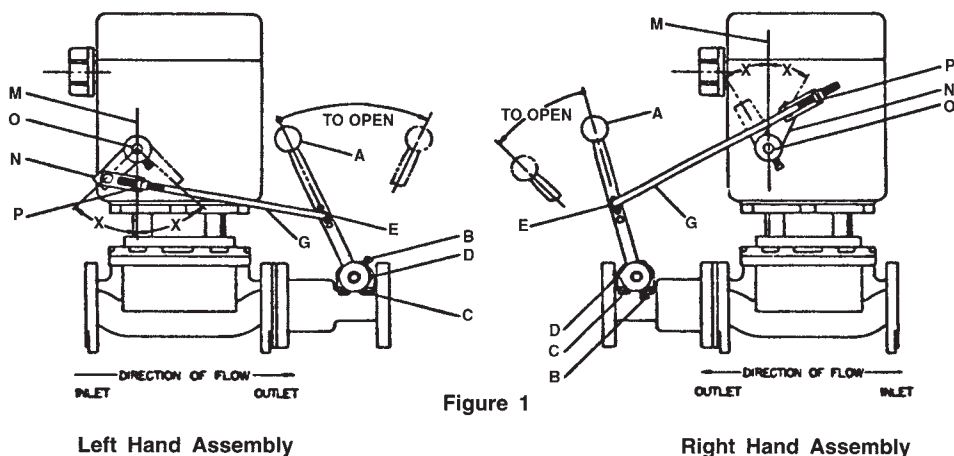

800 SERIES REGISTER

To Remove Register From Flowmeter

To Clean Register Masks

TO ROTATE THE REGISTER

Figure 1

1. Remove cotter pins (E) from valve linkage.
2. Unscrew the outside register link lock nut (P) and remove connecting rod (G).
3. Remove register link (N), rotate 1/2 turn and reassemble onto register as described in appropriate valve adjustment instructions (Page 6).
4. Loosen two clamp screws on lower front of register up and turn register 180°.
5. Remove four handle housing assembly hex screws (C) and remove handle housing assembly from valve.
6. Remove valve handle set screw (B) and slide handle off bushing. Remove two cam retaining screws (not shown). Remove shaft seal plug (D). Disassemble valve operating shaft and valve operating cam. Reassemble valve operating shaft and install valve operating cam in the reverse direction. Reinstall two cam retaining screws and shaft seal plug. Reinstall housing assembly with valve operating cam acting on pilot rod. Secure with four hex screws (C). Reassemble valve handle (A) on knurled knob in position as shown for specific assembly.

After completing the above instructions, the valve linkage must be adjusted in accordance with the procedure for the specific type valve as outlined on the following pages.

1" MP FLOWMETER WITH SINGLE TRIP AND DOUBLE TRIP AUTO-STOP VALVE

Note: Before any adjustment of the Double Trip or Single Trip Auto-Stop Valve is made, be sure that the Auto-Stop setting wheels indicate a quantity, other than zero, to insure that the trip mechanism of the register is in proper position.

To Adjust Double Trip Valve Linkage With Valve At Outlet of Flowmeter (See Figure 2)

1. Depress the emergency stop button on the register and turn the shaft (O) clockwise (as viewed from rear of register.)
2. Assemble register link (N) on knurled knob in position as shown for specific assembly. (See Figure 2). Arm should move an equal distance each side of vertical center line (M) (Angle $x=x$).
3. Assemble one nut (P) on connecting rod (G) and the other end of the connecting rod to the center hole in handle (A) using washers and cotter pins (E).
4. Open valve all the way. Turn shaft (O) counter clockwise to latch up mechanism. With valve held open, tighten nut (P) against register arm link. Then assemble and tighten second nut at (P).
5. Depress the emergency stop button and allow the valve to close. At this point the linkage between the valve and the register must be free. If it is not, the above adjustments must be rechecked.
6. Set the register to deliver the minimum quantity and open the valve to run product through the flowmeter.
7. After the initial trip occurs the valve should close to the intermediate flow position. This rate will vary depending on product metered. If the valve closes too far, or all the way, adjust nuts (P) to provide additional rod length.

1" MP FLOWMETER WITH SINGLE TRIP AND DOUBLE TRIP AUTO-STOP VALVE

Adjustment of 1" Double Trip Auto-Stop Valve

8. It is sometimes necessary to change the position of the handle. This can be done by loosening handle screw (B) and repositioning the handle as follows: If the register mechanism will not latch up, position the handle further toward the register. If the valve will not close, the handle may be positioned away from the register. Fine adjustments may be made by changing the effective length of connecting rod (G) utilizing nuts (P). The rod length (G) may also be varied by positioning the end of the rod in the upper or lower holes in the valve handle.
9. The Auto-Stop strip adjusting screw should be near its mid-position. (Also see page 14 "To Adjust the Tripping Point,")

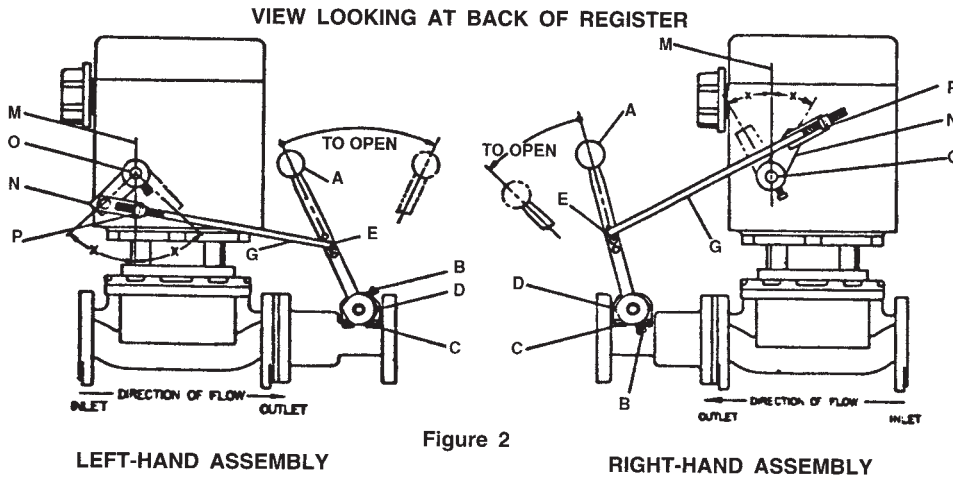

Figure 2

2" MP FLOWMETERS WITH SINGLE TRIP AND DOUBLE TRIP AUTO-STOP VALVES

In determining whether the metering unit is a Right Hand or Left Hand Assembly, the position of the outlet of the flowmeter as the operator faces the front of the register, is the governing factor.

When the flowmeter is assembled as a Left Hand Assembly and it is desired to change it to a Right Hand assembly, or vice versa, proceed as follows:

1. Remove clevis pin (E) from valve linkage.
2. Unscrew the outside register link lock nut (P) and remove connecting rod (G) and clevis (F) as a unit.
3. Remove register link (N), rotate 1/2 turn and reassemble onto register as described in appropriate valve adjustment instructions. (Pages 7 & 8.)
4. Loosen two clamp screws on lower front of register, lift register up and turn register 180°.
5. Remove operating shaft cap screw (C) on both sides.
6. Interchange connecting rod arm (H) and valve operating handle (A). The connecting rod arm must be assembled with notches (J and K) in specific relationship. (See item 3 of valve adjustment instructions for details regarding position of notches.)
7. Reassemble operating shaft cap screws (C).

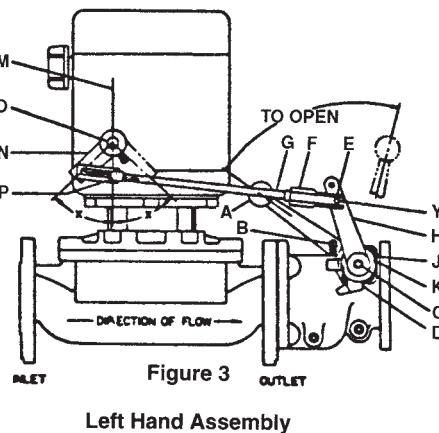

2" MP FLOWMETERS WITH SINGLE TRIP AND DOUBLE TRIP AUTO-STOP VALVES

To Rotate the Register

Figure 3

8. Remove valve handle stop set screw (B) and screw into holes on opposite side of valve.

After completing the above instructions, the valve linkage must be adjusted in accordance with the procedure, for the specific type valve (*i.e. Double Trip or Single Trip*) as outlined on pages 7 & 8.

Note: Before any adjustment of the Double Trip or Single Trip Auto-Stop Valve is made, be sure that the Auto-Stop setting wheels indicate a quantity, other than zero, to insure that the trip mechanism of the register is in proper position.

1. Depress the emergency stop button on the register and turn the shaft (O) clockwise (as viewed from the rear of the register).
2. Assemble register arm (N) on knurled knob in position as shown for specific assembly. (See Figure 4). Arm should move an equal distance each side of vertical center line (M) (Angle $x=x$).
3. Assemble valve arm (H) as shown for specific assembly. On the right hand assembly there must be one notch between the cast mark (K) on the valve arm and the cast mark (J) on the stop plate (J and K). On the left hand assembly these cast marks must be in line.
4. Assemble one nut (P) on connecting rod (G) and assemble clevis to the other end of the connecting rod a distance of 1".
5. Insert end of connecting rod through register arm link and assemble clevis (F) to valve arm (H) using upper hold. (See Figure 4). Insert clevis pin (E).
6. Open valve all the way. The opening of the valve is stopped by the set screw (B) which should project approximately 1/8" below the lug holding it. Turn shaft (O) counter clockwise to latch up mechanism. With valve held open, tighten nut (P) against register arm link. Then assemble and tighten second nut at (P).
7. Depress the emergency stop button and allow the valve to close. At this point the linkage between the valve and the register must be free. If it is not, the above adjustments must be rechecked.
8. Set the register to deliver the minimum quantity and open the valve to run product through the flowmeter.
9. After the initial trip occurs the valve should close to the intermediate flow position. This rate will vary depending on product metered. If the valve closes too far, or all the way, unscrew clevis (F) on rod (G) to hold valve open further. If the rate of flow is too fast during the intermediate position, turn the clevis onto the rod to allow the valve to close further. It should not be necessary to turn more than one turn in either direction.
10. It is sometimes necessary to change the position of set screw (B) if the clevis has been readjusted. If the register mechanism will not latch up, unscrew the set screw to allow the valve to open further. If the connecting rod (G) is under compression, when the valve is held all the way open, turn the set screw down to relieve the pressure on the register.
11. The Auto-Stop trip adjusting screw should be near its mid-position. If a small adjustment of this screw will not permit the register to shut off "on the mark," it is usually possible to correct this by a slight adjustment of the clevis (F). This will move the main valve nearer to or further away from its seat during the intermediate flow and thereby change the amount of time needed for the valve to fully close at the last trip. (*Also see page 14, "To Adjust the Tripping Point."*)

Adjustment of Auto-Stop Valve

To Adjust Double Trip Valve Linkage with Valve at Outlet of Flowmeter

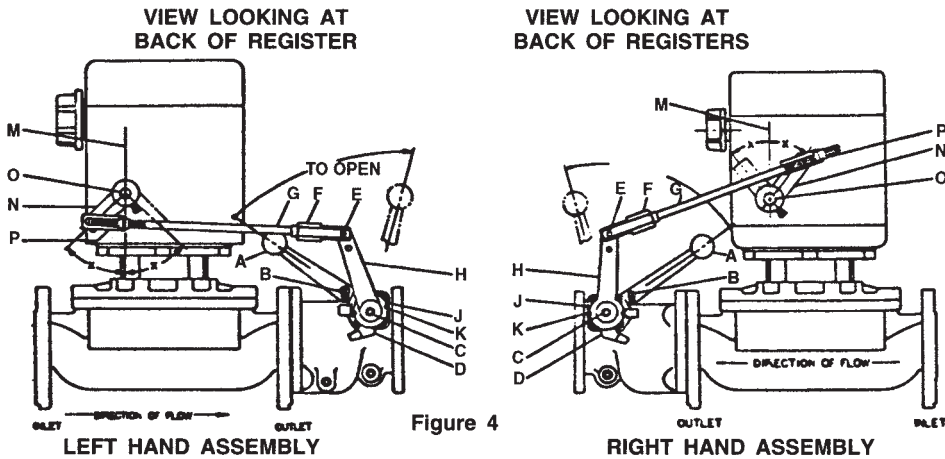

Figure 4

Note: If it is difficult to obtain proper rate of flow during intermediate trip position and still have register latch up fully, check Auto-Stop valve to ensure that it is opening all the way. Check valve by removing set screw (B) and clevis (F) from valve arm; open valve as far as possible. The distance between lug on arm and lug on stop plate must be made more than 1/4".

Note: Before any adjustment of the Double Trip or Single Trip Auto-Stop Valve is made, be sure that the Auto-Stop setting wheels indicate a quantity, other than zero, to insure that the trip mechanism of the register is in proper position.

To Adjust Single Trip Valve Linkage

1. Depress the emergency stop button on the register and turn the shaft (O) clockwise.
2. Assemble register link (N) on knurled knob in position as shown for specific assembly. (See Figure 5). Arm should move an equal distance each side of vertical center line (M) (Angle $x=x$).
3. Assemble valve arm (H) as shown for specific assembly. On the right hand assembly there must be two notches between the cast mark (K) on the valve arm and the cast mark (J) on the stop plate (J and K). On the left hand assembly there must be one notch between marks (J above K).
4. Assemble one nut (P) on connecting rod (G) and assemble clevis to the other end of the connecting rod a distance of 1".
5. Insert end of connecting rod through register arm link and assemble clevis (F) to valve arm (H) **using lower hole (Y)**. Insert clevis pin (E).
6. Open valve all the way. The opening of the valve is stopped by the set screw (B) which should project approximately 1/8" below the lug holding it. Turn shaft (O) counter clockwise to latch up mechanism. With valve held open, tighten nut (P) against register arm link. Then assemble and tighten second nut at (P).
7. Depress the emergency stop button and allow the valve to close. At this point the linkage between the valve and the register must be free. If it is not, the above adjustments should be rechecked.

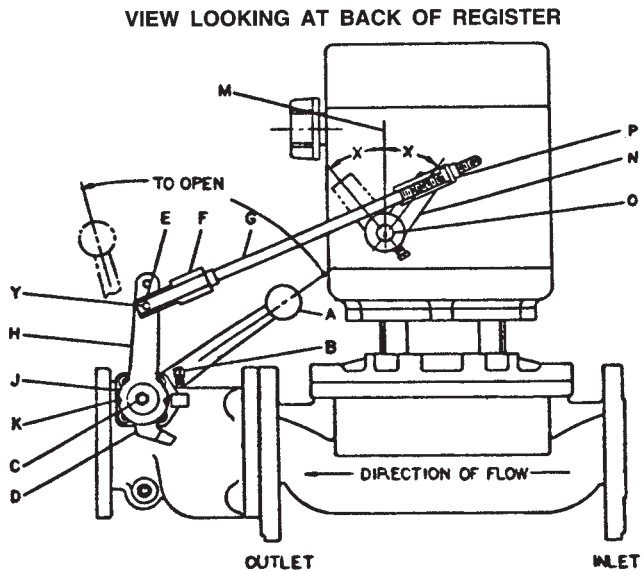

**Figure 5
RIGHT-HAND ASSEMBLY**

Figure 5

TO ROTATE THE REGISTER (3" MP)

Remove the register from the flowmeter. Two studs and two threaded holes will be seen on the top of the gear train. To turn the register 90° transfer the studs to the empty holes. To turn the register 180°, do not change the location of these studs. Replace register in the desired position and tighten the screws at the front of the register.

When the flowmeter is assembled as a Right Hand Assembly (outlet and valve assembly to the right as you face the register dial) and it is desired to change to a Left Hand Assembly (outlet and valve assembly to the left as you face the dial), proceed as follows:

1. Disconnect the connecting rod at "G" by removing cotter pin, washer, and clevis pin.
2. Remove the outside connecting rod nut at "F".
3. Remove the register.
4. Remove the auto-stop valve and reposition on alternate flange connection at other side of flowmeter.
5. Replace the register to face in the desired position.
6. Remove connecting link arm on register and reassemble it so that it is in upward position, as indicated by dotted lines on Fig. 6 Arm should be in extreme clockwise position when emergency button is depressed.
7. Remove the valve handle and connecting rod arm from valve by removing screws at "N."
8. Exchange the valve handle and the connecting rod arm; the connecting rod arm is to be assembled to the valve with locating marks on arm and stop plate in proper relation as indicated in Figure 6.

TO ROTATE THE REGISTER

Non Preset Models

Preset Models

9. Check engagement of connecting rod in clevis; tis should be approximately 1". Attach connecting rod; do not tighten the nuts at "F."
10. Turn connecting link arm on register to its maximum counter-clockwise, full latched open position. Hold valve open and tighten two nuts at "F" on connecting rod. Depress emergency stop button at front of register and let valve close. Check dimension "A": which should be from 1" to 1-1/2". If this distance is not correct, change position of the connecting link arm on the knurled hub until this distance is obtained. Repeat step 10.
11. Insert set screw "S" in bracket at handle side of valve and adjust so that the valve latches full open but that the connecting rod remains loose when valve is held in its maximum full open position. Tighten nut on set screw.
12. Adjust intermediate rate of flow.
13. On Double Trip Valve clevis should be mounted in the top hole on the connecting rod arm. On Single Trip clevis should be mounted in the lower hole on the connecting rod arm.

The valve connecting rod is in adjustment when it is loose, both when the valve is completely closed and when the valve is held wide open manually. If it should for any reason get out of adjustment, proceed as follows:

To Adjust the Valve Connecting Rod

VIEW LOOKING AT BACK OF REGISTER

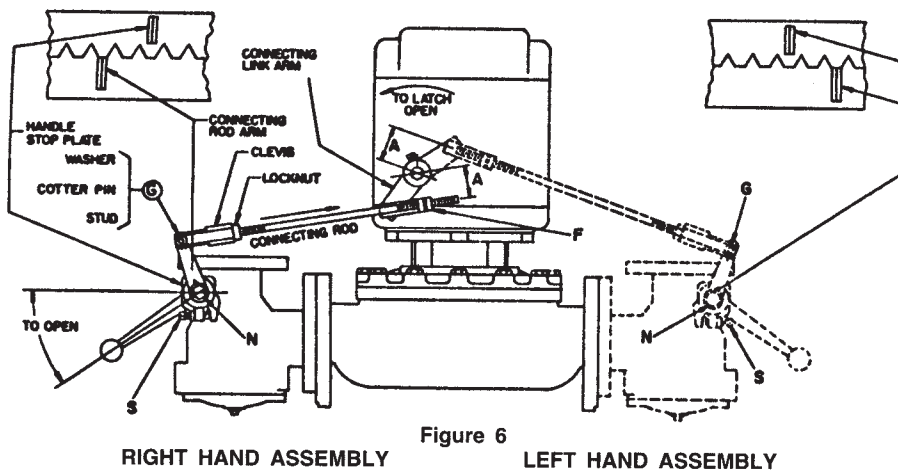

Figure 6

Loosen set screw "S", then tighten until the valve will latch full open but the connecting rod remains loose when valve is held in its maximum full open position. Tighten nut on set screw.

Press the setting buttons inward until the desired quantity is noted on the preset wheels.

Pushing the red emergency stop button will trip the valve. After it has been used the mechanism may be set for a new future or the delivery may be completed automatically as originally set by re-opening the valve except if the flow has been stopped with 40 gallons or less remaining. In this case, the delivery can be completed by manually holding the valve partially open.

To Set the Preset Mechanism To Stop in Emergency

Registers are shipped from the factory with the Preset mechanism adjusted to trip correctly at the normal rates of flow. If due to a change in the speed of closing of the valve or for any reasons the Preset does not trip off at the correct point, the trip point may be adjusted as follows:

If the valve is closing "off the mark," either late (over-delivery) or early (under-delivery), adjust the clevis (see Fig. 6) in half-turn increments to bring the trip point to the zero mark. For right-hand assemblies, turn the clevis to lengthen the connecting rod when the trip point is early, or turn to shorten if the trip point is late. For left-hand assemblies turn in the opposite direction. Continue this procedure until the final trip is on or close to the zero mark. The set-screw "S" (Fig. 6) must also be readjusted as described in "To Adjust the Valve Connecting Rod." The intermediate flow rate will be satisfactory when the final trip is adjusted, as described.

Further adjustment of the trip point is possible, but is not recommended for normal applications. The following procedure should be used only when very exact setting of the final trip is necessary.

Adjust the clevis, as described above, and proceed as follows:

Remove the trip adjusting screw located in the lower right corner of the register from housing (See Fig. 7). Insert a narrow blade (3/16") screwdriver until it engages the slotted head of the adjusting screw. One turn of this screw will change the tripping point about one-quarter of one-tenth gallon.

If the preset trips before reaching the zero mark (late), turn counter-clockwise.

Do not turn off the adjusting screw more than 1-1/2 turns in either direction from the initial position or past a point where a resistance to further turning of the screw is felt.

If the trip point is not on zero after 1-1/2 turns, return the adjusting screw to its original position and turn the clevis a half turn in the appropriate direction. Then repeat the trip screw adjustment procedure.

OPERATING AND MAINTENANCE INSTRUCTIONS FOR AUTO-STOP VALVE (3" MP)

The 3" Type 1 Auto-Stop Valve is designed to be used with the 800 Series Register on MP Flowmeters. The use of this valve makes it possible to obtain accurate cut-off without subjecting the flowmeter and pipes to undue shock pressure.

To Adjust the Tripping Point

Figure 7



Figure 7
OPERATING KNOB

OPERATING AND MAINTENANCE INSTRUCTIONS FOR AUTO-STOP VALVE

General Information

OPERATION

With the main valve and the pilot valve closed, the inlet pressure and the spring keep the valve closed. To open the valve, the handle is lifted, lifting the pilot valve off its seat. Inlet pressure within the cylinder is dissipated through the pilot valve to the outlet, so that a difference in pressure exists between top and bottom of the piston. This pressure differential will open the main valve.

To close the valve, the handle is released and the spring closes the pilot valve. Inlet pressure is admitted into the cylinder through a needle valve, and the main valve will move to its intermediate position, determined by the position of the pilot valve.

In operation, the first trip will occur with 40 gallons still to be delivered. The valve should reach its intermediate position with between 10 and 20 gallons still remaining to be delivered. This will depend largely on field conditions but may be adjusted by means of the needle valve (see below "To Adjust Rate of Closing of Valve from its Full Open Position to the Intermediate Position.") The rate of flow through the valve when in its intermediate position should not exceed 50 gpm. (To adjust intermediate rate of flow see below.) This rate is controlled in the valve and will vary, depending on such field conditions as pressure, etc. It is important that the needle valve be adjusted so that the valve reaches its intermediate position before the final trip takes place. The final trip may be adjusted as shown on page 10, Figure 6.

1. Set register setting wheels for 100 gallons and open valve. After first trip occurs (40 gallons remaining) valve closes to the intermediate position. To hold valve in its intermediate position index thousand wheel one number; this is done by pushing left hand preset button.
2. Remove cotter pin, washer, and clavis pin at "G" (Figure 6, page 10) and adjust clevis by screwing off until a mere leak is passing through the valve. Turn clevis eight turns to shorten the length of the connecting rod assembly.
3. Check intermediate rate of flow. If the intermediate rate of flow exceeds 50 gallons per minute, lengthen connecting rod assembly until an intermediate rate of flow 50 gallons per minute or less is obtained.
4. Tighten clevis lock nut.
5. Readjust set screw "S" as outlined on page 10, under heading "To adjust the Valve Connecting Rod."

Remove seal screw (28). To make the valve close faster, turn needle valve at (N) counter-clockwise. To make the valve close slower, turn needle valve clockwise. Valve is in correct adjustment when intermediate position of valve is reached with between 10 and 20 gallons still remaining to be delivered. Replace seal screw. Check final trip.

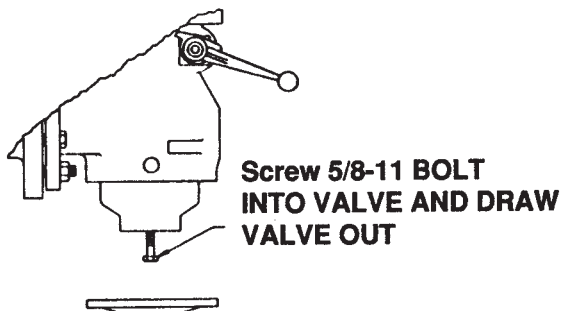

Figure 8

OPERATION

To Adjust Intermediate Rate of Flow

To Adjust Rate of Closing of Valve from its Full Open Position to the Intermediate Position

Figure 8

1. To disassemble valve, remove cover (43) from end of valve. (Refer to figure 9).
2. Remove cylinder retaining screw (25), seal screw (28) and needle valve (27).
3. Using a 5/8" bolt, screwed loosely into tapped hole in end of cylinder (38), pull cylinder and piston assembly through end of valve body.
4. By removing 2 screws (34), piston assembly may be removed from cylinder. (Caution: Depress the piston to remove spring tension from screw). Pilot valve and spring are loose and care must be taken that they are not damaged or lost.
5. Remove the four screws (39). This will release the throttling ring. Valve disc may now be replaced.

To Disassemble Valve

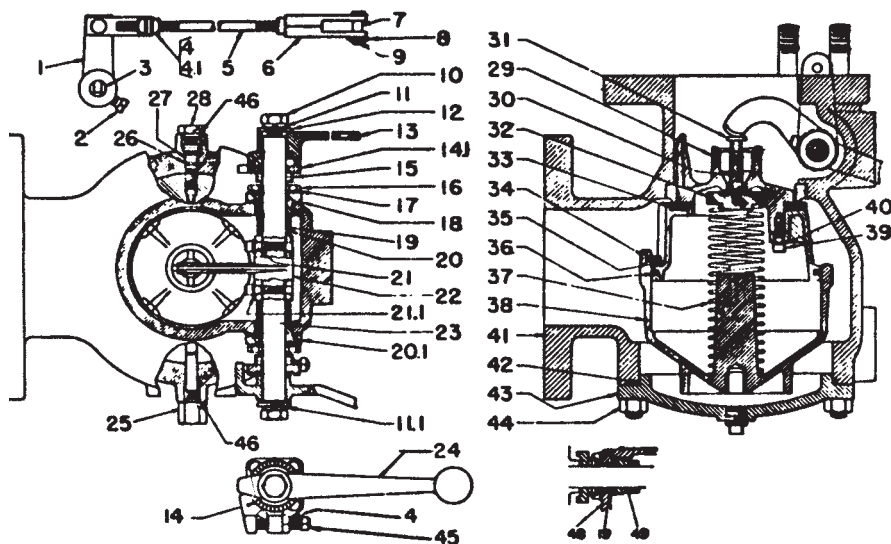

Figure 9

OLD CONSTRUCTIONS

Figure 9

1. Clean all parts thoroughly.
2. Replace valve disc and reassemble throttling ring to position with four screws (39). Screws must be tightened so that metal to metal contact takes place between the piston and throttling ring.
3. Place pilot valve over rod and assemble spring in position over pilot valve and post in cylinder. By locating piston ring so that the two extensions on either side of cylinder will tend to force the piston ring into its slot, slight pressure will force the piston assembly into the cylinder. Two screws (34) may now be put in position. Care must be taken that these screws enter the cast slots on either side of piston to prevent turning of piston within cylinder.
4. Complete piston and cylinder assembly may now be reinserted into the valve body. Care must be taken when installing this unit so that the piston guides are not bent, which happens if the piston is cocked in the cylinder. To prevent this, it is best to see that the piston is out all the way, resting against the two screws (34). Care must also be taken to make sure that before placing cylinder retaining screw in position, the needle valve hole in the cylinder lines up with the proper hole in the valve body. This is shown by the word "adjust" on the outside of casting. The retaining screw (25) may be reinstalled and needle valve and seal screw installed.
5. Replace "O" ring cover gasket and cover.
6. Connect to register and adjust links (Fig. 6).
7. Adjust rate of closing (see page 12).

To Reassemble Valve

1. This may be caused by worn "O" ring (19). To replace, remove screw (10), connecting rod arm, handle and stop plate (14). Then knock out drive pin (15). In doing this be sure that shaft is supported so that it will not be bent. Remove four screws and pull out shaft bearing bracket (20.1).
2. A new "O" ring (19) may now be installed. While bearing is removed, inspect shaft to be sure it is smooth and free of nicks and the "O" ring groove is clean.
3. Replace shaft bearing and assemble other parts in order removed.

Remove cover of valve and then the valve mechanism, then the piston and cylinder assembly. Inspect the valve disc for dirt or nicks. If valve disc (33) needs replacing, valve may be disassembled and new disc installed. While valve is apart, pilot valve (32) should be inspected and replaced, if necessary.

ALL MODELS

The flowmeter is shipped from the factory with Auto-Stop mechanism adjusted to trip correctly at maximum rates of flow while the flowmeter is measuring a non viscous liquid. Trip adjustment after final installation may be necessary due to differing flow rate and/or viscosity.

If the Auto-Stop does not trip off at the correct mark due to a change in the speed of closing of the valve, different rates of flow, or any other reason, the adjustment is made as follows:

Remove the screw located in the lower right corner of the front housing. Insert a medium-sized screw driver into this hole until it engages the slotted head of an adjusting screw. One turn of this screw will change the tripping point about one-quarter of one graduation of the first wheel.

If the Auto-Stop trips before reaching the zero mark, turn the adjusting screw in a clockwise direction.

If the Auto-Stop trips after the zero mark, turn the adjusting screw in a counter-clockwise direction.

In some instances on Double Trip Valves an adjustment of the valve linkage may be required in order to have the Auto-Stop at the correct point. (See page 7).

600 SERIES REGISTER

Register parts are such that only minor field repairs are advisable. When a register is in need of repair or service other than that for which instruction is given here, it should be returned to a Itron authorized distributor. Maintenance of the register is limited to cleaning and to those operations which will locate the sources of possible troubles without removing the register from the flowmeter.

Remove the four register mounting screws. Rotate to the desired position and reinstall screws.

- 1) Remove the two cover plate screws (#1).
- 2) Push in reset knob and partially reset to retain shaft in reset position (#2).

If Leakage Occurs Around Valve Shaft

If Main Valve Does Not Shut Off Tight

ALL MODELS To Adjust the Tripping Point

600 SERIES REGISTER Repair of Register

To Rotate the Register

To Remove Housing from Mechanism

- 3) Remove reset knob screw (#3) and four screws on bottom plate (#4).
- 4) Pull out on reset knob to disengage knob from shaft.
- 5) Loosen and slide housing to knob end and remove. Caution is advised in removal of housing to avoid scraping visible wheels.
- 6) Reset shaft can be turned to normal position.

Regularly clean the housing to remove accumulations of dirt and grease, food products or chemical deposits. **CAUTION:** Use only mild detergents and water to clean the register window. Do not use abrasives or spray type cleaners, or solvents and thinners which may soften or cloud the plastic window.

- 1) Remove the housing from the mechanism.
- 2) Blow out the dirt with compressed air. Do not use brushes.

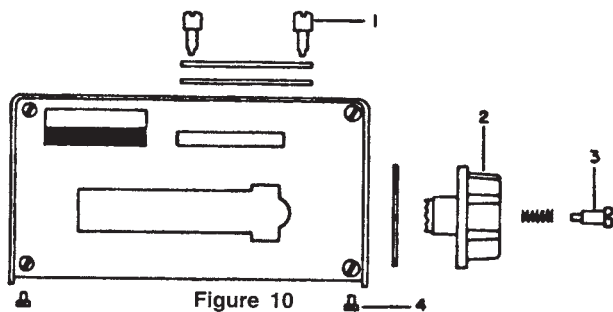

Figure 10

Note: Large magnetic drive assembly accompanies the 600 series register.

OPERATIONAL CHECKS

Two general operational checks are performed on all Registers: calibration and reset mechanism operation.

- 1) **CALIBRATION CHECK** - Check the calibration of the Register and recalibrate, if necessary. While pumping liquid through the flowmeter during calibration, observe that the register wheels and totalizer wheels advance properly, that registration is consistent and not erratic, and that the wheels are not discolored or defaced.
- 2) **RESET MECHANISM CHECK** - Check the resetting of the Register by pushing on and rotating the reset knob clockwise (*as viewed from the right*) to its stop, and releasing it. Note that the register wheels index to read 0000.0 on the 1" & 2" and 00000 on the 3", and that they align in a straight line. Note that the shutter swings freely to mask the wheels as they rotate, and drops completely when resetting is complete. (**Note: Does not apply to 1/2" MP.**)

GEAR TRAIN MAINTENANCE

This gear train is constructed in such a way that the actual gear train may be removed from the housing for general cleaning by removing the screws through the gear train top plate. An Itron distributor can provide replacement gear trains if required, but proper cleaning and lubrication of the gears and shafts can greatly extend the useful life of the gear train. We recommend removing dirty grease or accumulation with a suitable solvent applied by a brush and relubricating with light grease applied to the gear shafts and bearings.

Cleaning

To Clean the Register

Figure 10

OPERATIONAL CHECKS

General

GEAR TRAIN MAINTENANCE

800 Series Register

600 Series Register

Replacement gear trains and related parts should be ordered from the parts list, for P150.

CLEANING THE FLOWMETER

Due to the simple design of this flowmeter, there are very few internal parts to the flowmeter. There are not parts that would normally require maintenance or replacement, but periodic cleaning and inspection are recommended to lengthen the flowmeter's useful life.

Since there is no separate measuring chamber, simply remove the eight main case bolts and remove the cover assembly. Carefully remove the specially encapsulated "O" ring from its groove for cleaning and re-use. With the cover removed, the piston may be easily lifted out for inspection and wiping clean. Check the control roller to see that it fits closely but rotates easily on the chamber pin. Also check to see that the diaphragm and seal pin fit snugly in their positions. Clean by wiping with a soft, lint free rag all interior surfaces of the chamber area.

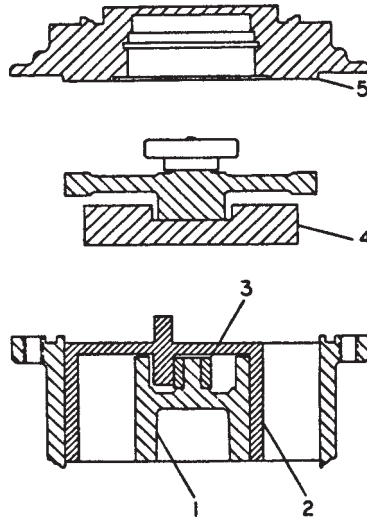

1. Maincase
2. Piston Assembly
3. Control Roller
4. Magnetic Drive Assembly
5. Cover

Figure 11

To inspect the magnetic drive assembly, remove the hex socket screws which attach the seal plate to the cover. Then, using needle nose pliers or other suitable tool, remove the retaining ring which holds the magnetic drive assembly in position. Remove the magnetic drive assembly and inspect for excessive wear of the shaft or bearing by observing the "wobble" of the shaft. If more than .020" of wobble is noticed, the assembly should be replaced. Also notice the wear on the magnet insert curved surface. Carefully wipe all parts and make sure the assembly rotates easily before reinstalling in the cover.

CLEANING THE FLOWMETER

To Clean Measuring Chamber Area

Figure 11

To Inspect the Magnetic Drive Assembly

GENERAL MAINTENANCE

To maintain accuracy of Itron MP Flowmeters, little is necessary other than to see that the proper conditions of operation are observed. Once the flowmeter has been installed correctly, these conditions consist merely in guarding against foreign matter, such as air or sediment entering the flowmeter. However, should any malfunction develop, do not dismantle the flowmeter until the cause of trouble has been determined. Refer to the section marked "Troubleshooting," page 18.

The liquid passing through the MP flowmeter must be free of grit and other forms of sediment to prevent unnecessary friction and to eliminate scoring of the piston and chamber walls. Evidence of trouble from this source will be found in under-registration of the flowmeter. Periodic cleaning and inspection of the strainer will help to insure against this type of trouble.

Being an instrument that measures by volume, a flowmeter will record the passage of air as well as the liquid being measured. Over-registration is the result of air in the piping system.

Incidental water will cause no damage to the flowmeter. Possibilities of freezing, however, may be expected when water is allowed to remain in the flowmeter in exposed areas.

Water in the register will cause trouble particularly in cold weather when ice may form and cause jamming. As in the case of most instruments, some protection for the register should be considered when making the installation.

Instructions for testing are given in the Calibration section. Test with 10 gallon test measure of approved design (for 1/2" MP) or test with 100 or 300 gallon test measure of approved design (for larger sizes).

Before a flowmeter is put in storage it should be wiped clean and dry to prevent buildup of possibly corrosive deposits.

GENERAL MAINTENANCE

Sediment

Air

Water

Testing

Storage

TROUBLESHOOTING

TROUBLESHOOTING

Register Not Working When Liquid is Flowing

- a) Bypass around flowmeter not shut off.
- b) Frozen condensation inside register.
- c) Register in need of repair.
- d) Sheared key on change gear.
- e) Defective magnetic drive assembly.

Chronic Leakage at the Main Case "O" -Ring

- a) Pump bypass stuck open.
- b) Damaged "O" -ring or loose bolts.

Reduction in the Flow Rate or Complete Stoppage of Discharge

- a) Pump bypass stuck open.
- b) An open valve in the piping allowing liquid to circulate around the pump.
- c) Worn pump.
- d) Blocked strainer due to sediment or frost.
- e) Piston in flowmeter stuck, caused by dirt. Check strainer and clean measuring chamber.

Over-Registration - Erratic

Air entering system and passing through flowmeter.

Under-Registration - Erratic

- a) Dirt in measuring chamber.
- b) Badly worn control roller or diaphragm.
- c) Flowmeter casing distorted or damaged.
- d) Leakage around the flowmeter due to partly open bypass valve.

Consistent Over- Or Under-Registration

Flowmeter in need of calibration.

**DIMENSIONAL DATA
SIZE 1/2"**

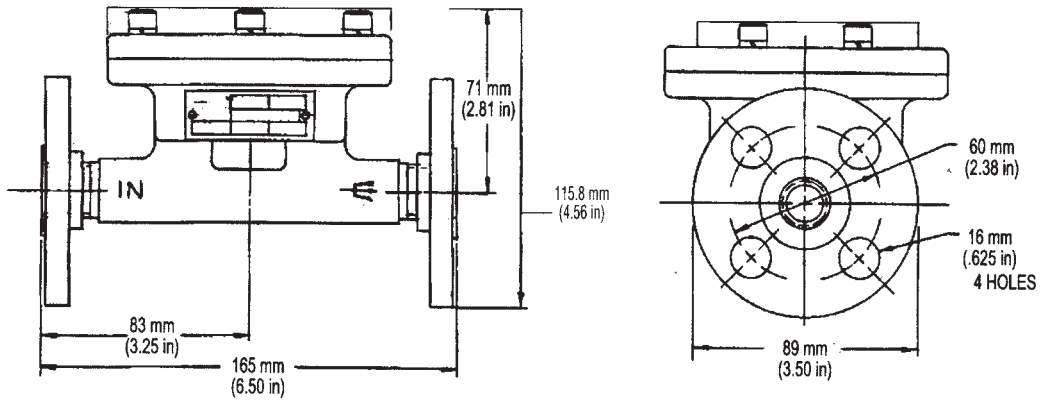

1/2" TYPE MP

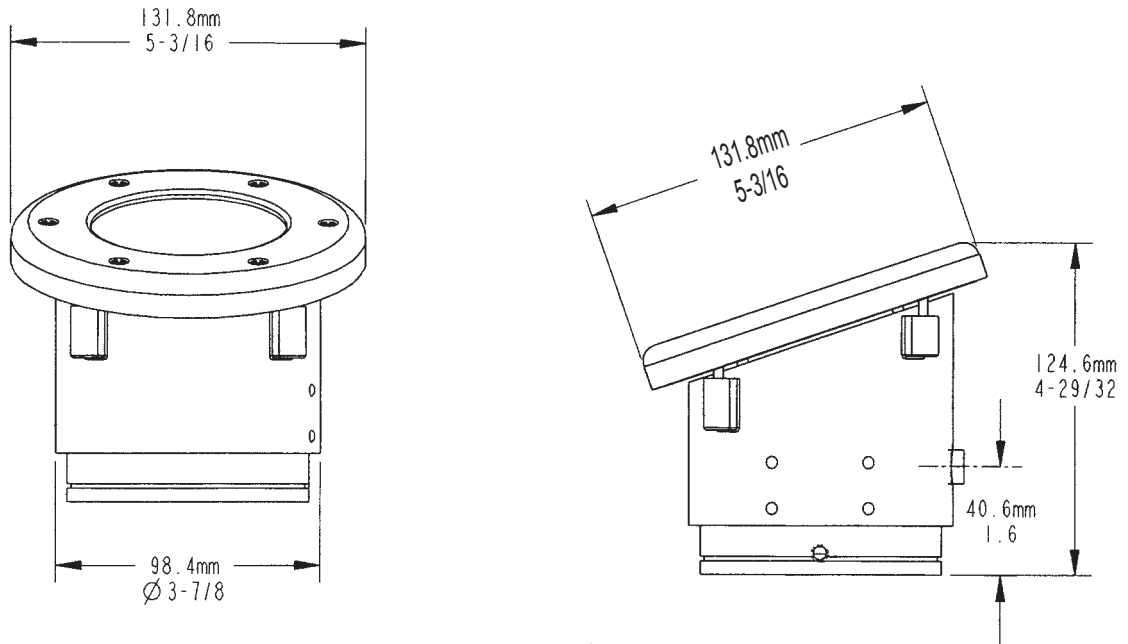

PULSMATE

1" DIMENSIONS

1" Type MP with 600 Series Register and Model 45 Pulse Transmitter

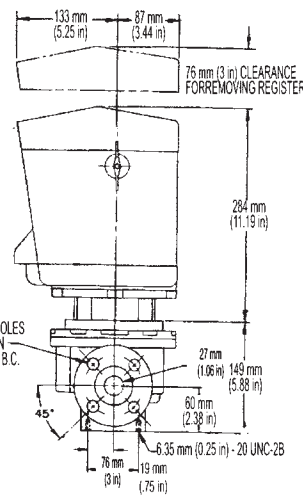
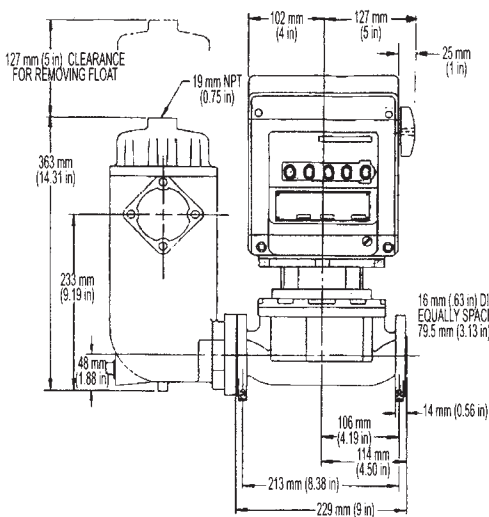
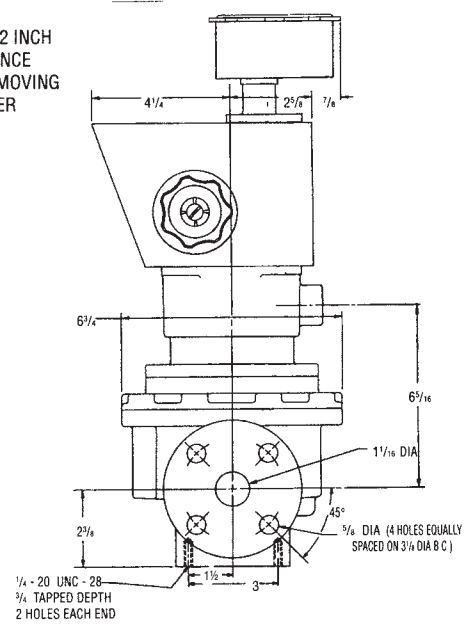
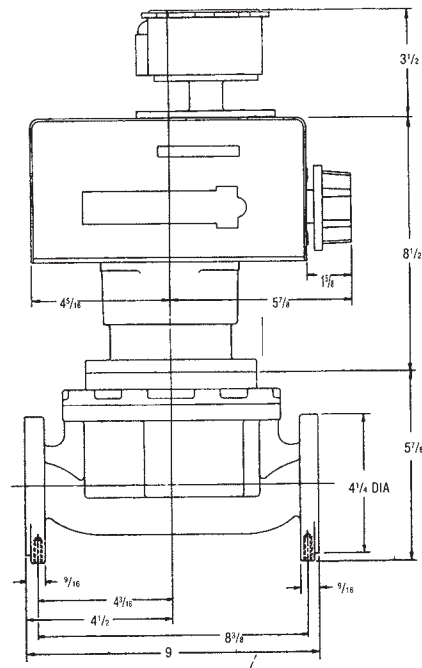

1" Type MP with 800 Series Register and Air Release/Strainer

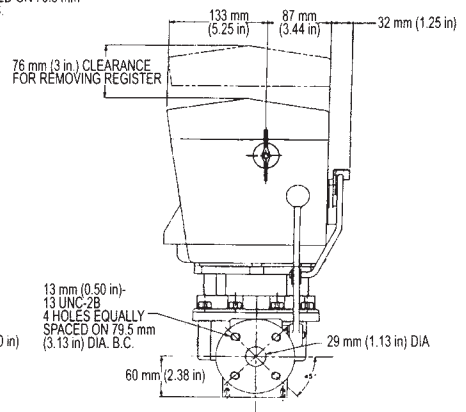
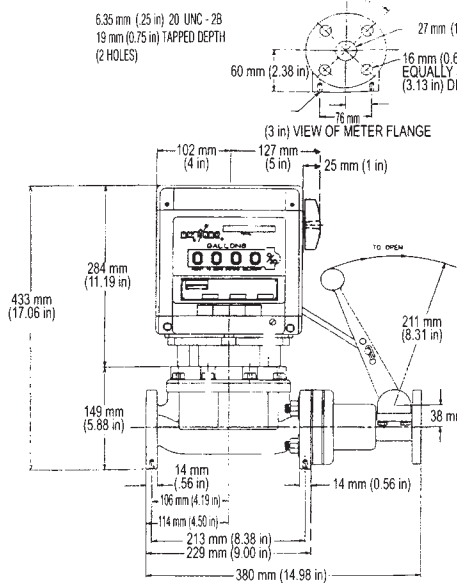
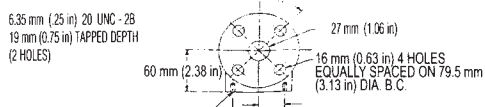

1" Type MP with 800 Series Register and Auto-Stop Valve

2" DIMENSIONS

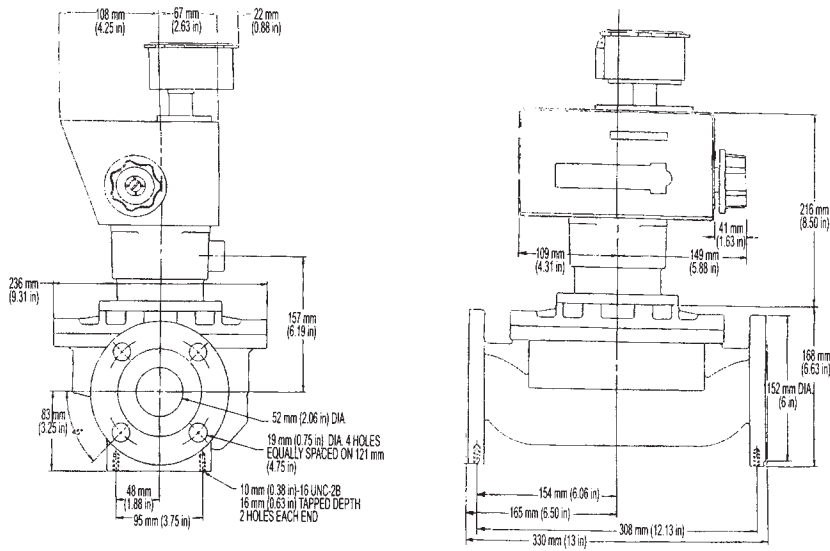

2" Type MP with 600 Series Register and Model 45 Pulse Transmitter

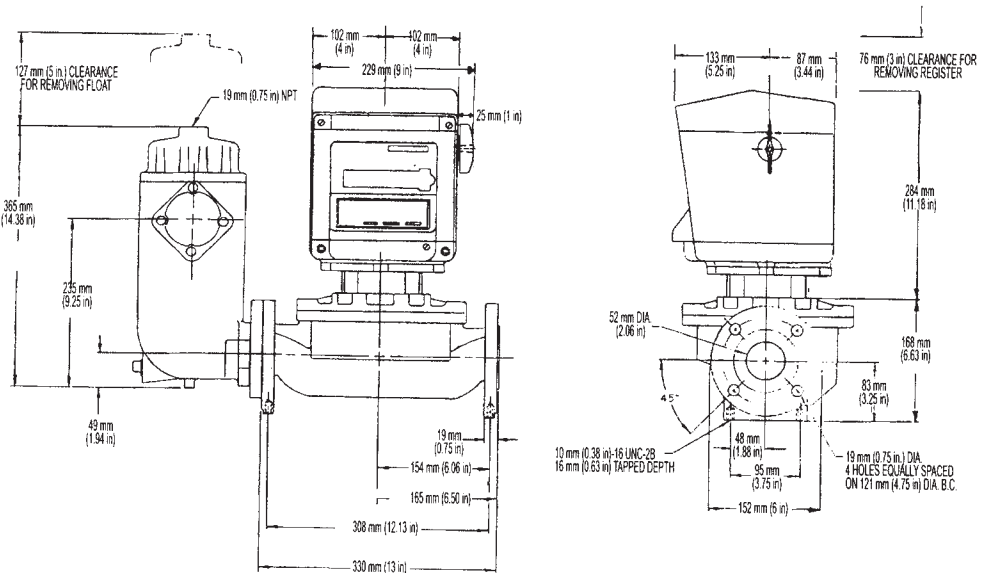

2" Type MP with 800 Series Register and Air Release/Strainer

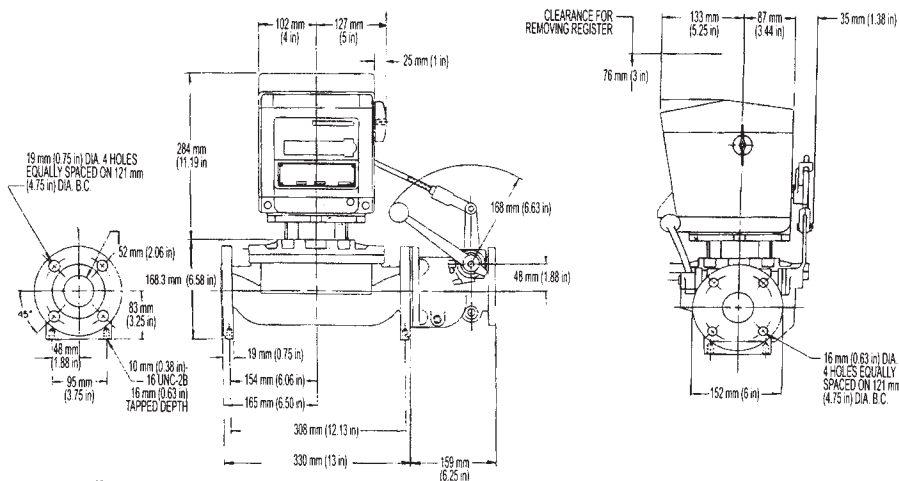

2" Type MP with 800 Series Register and Auto-Stop Valve

3" DIMENSIONS

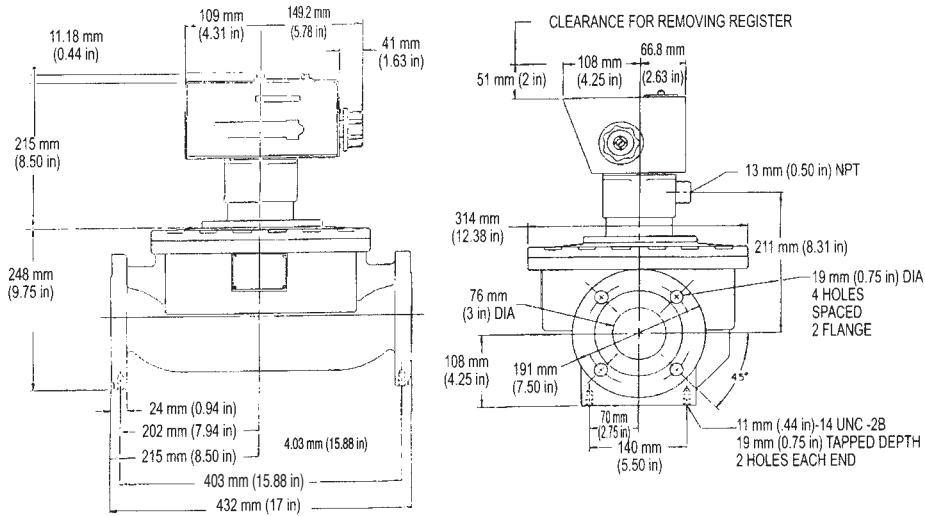

3" Type MP with 600 Series Register

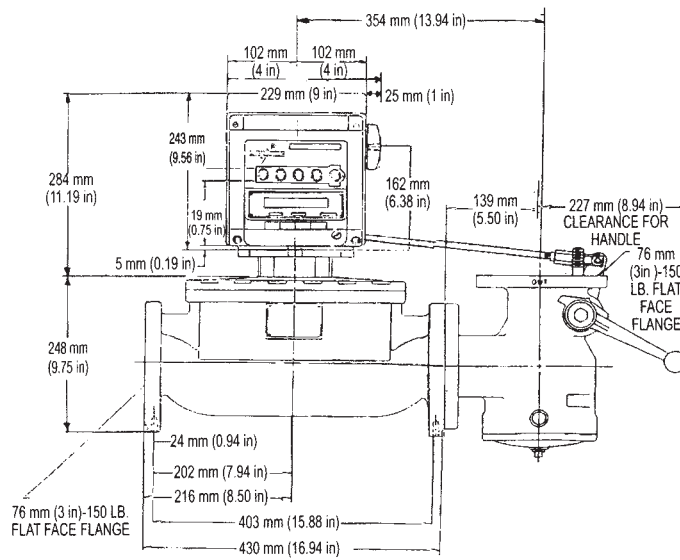

3" Type MP with 800 Series Register and Auto Stop Valve

U.S.A./International

1310 Emerald Road
Greenwood, SC 29646-9558
Tel.: Toll-Free (800) 833-3357
(864) 223-1212
Fax: (864) 223-0341

© 2009 Itron, Inc. 500 12/09

Specifications subject to change without prior notification.

Itron!